

LED AREA LIGHT
-8TH GEN

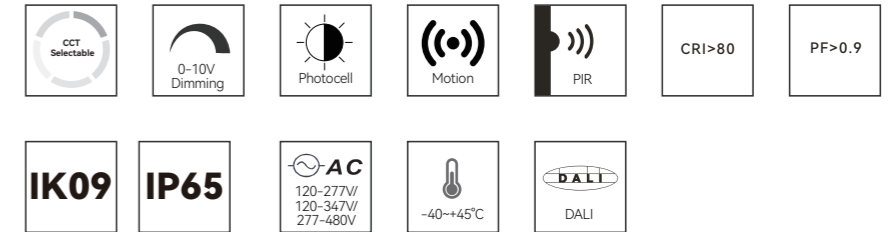

Features

- Streamlined shape---simple, clean and stylish. 3CCT & Wattage Selectable.
- UV resistant polycarbonate optical lens with high impact capability---IK09.
- Type III, Type V, Type IV lens interchangeable and rotatable. Fast and easy installation by 1 person.
- Multiple Installation Accessories for choice---Slip-fitter / Adjustable arm / Fixed arm / Trunnion / Yoke / Slip-fitter long arm / Fixed adapter arm.
- Excellent heat dissipation management ensures long life-span, with very low driver Tc point. Suitable for wet location.
- Great air-pressure management for avoiding distortion of the lens and water-proof failure over time.
- AC120-347V & 277-480V available. DLC 5.1 Premium and UL listed.

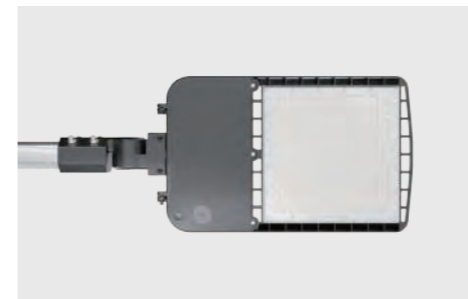

Accessories

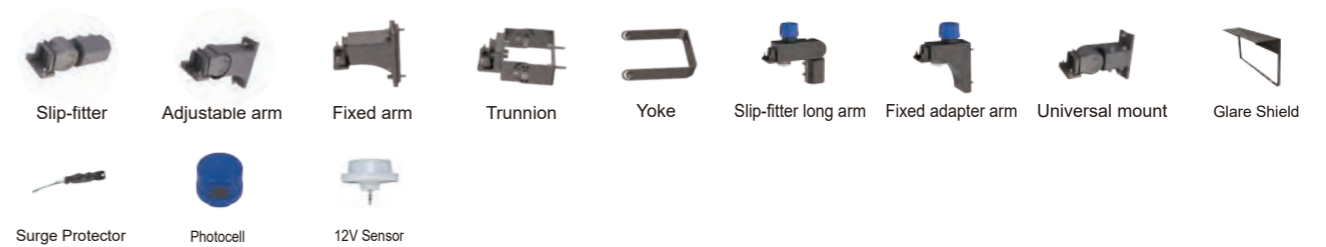

Dimensions

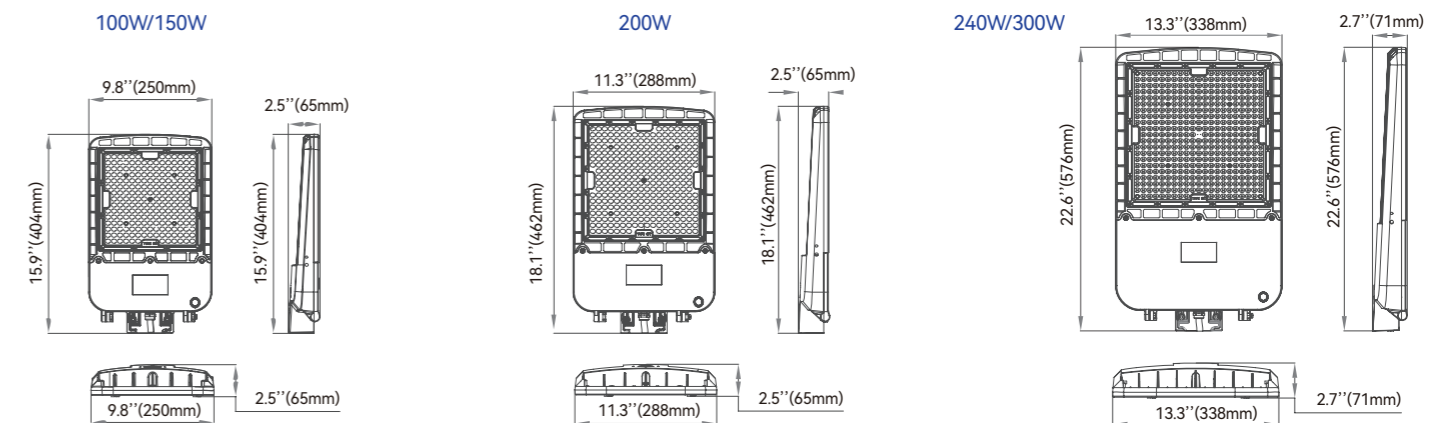

Specifications

Part No.	Input Voltage	Power	CCT	Lumens	Light Angle
TS-SL0810-100W-H3-50K	AC120-277V	100W	5000K	13,000lm	Type II Type III Type IV Type V
TS-SL0815-150W-H3-50K		150W		19,500lm	
TS-SL0820-200W-H3-50K		200W		26,000lm	
TS-SL0824-240W-H3-50K		240W		31,200lm	
TS-SL0830-300W-H3-50K		300W		39,000lm	
TS-SL0815-150W-H3-TCP	AC120-277V	150-100-70W	30-40-50K	19,500-13,000-9,100lm	Type II Type III Type IV Type V
TS-SL0820-200W-H3-TCP		200-150-100W		26,000-19,500-13,000lm	
TS-SL0824-240W-H3-TCP		240-200-150W		31,200-26,000-19,500lm	
TS-SL0830-300W-H3-TCP		300-240-200W		39,000-31,200-26,000lm	